

Block B - Proposed East Elevation
1 : 200

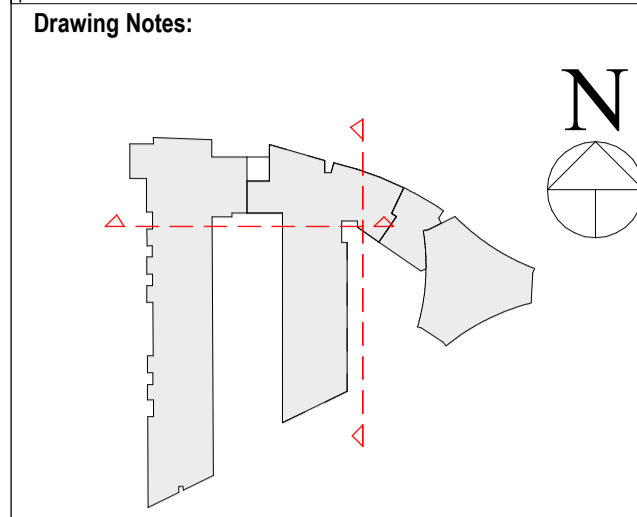

Block B+C - Proposed South Courtyard Elevation
1 : 200

Notes:
 - Do not scale from this drawing. Use figured dimensions in all cases.
 - Verify dimensions on site and report any discrepancies to the Architect immediately.
 - This drawing is to be read in conjunction with the Architect's Specification.
 - © This drawing is copyright and may only be reproduced with the Architect's permission.



- SITE BOUNDARY**
- AREA TO WHICH THIS APPLICATION RELATES**

Materials Legend

1. SELECTED OAT BRICK
2. SELECTED DARK BRICK
3. SELECTED METAL CLADDING
4. SELECTED RENDER
5. SELECTED LIGHT BRICK
6. PRE-CAST FACADE
7. PRE-CAST CILL
8. ALUMINIUM WINDOW

Rev.	Date	Drawn	Details of Issue / Revision
P01	20.03.2026	RAU	Issued for Planning

Dartry Mills,
 Dartry Road
 Dublin 6,
 D06 Y0E3
 T: +353 (0)1 498 7000
 W: www.reddyarchitecture.com
 E: info@reddyarchitecture.com

Client Details:
 Ruirside Developments Ltd

Project Details:
 Parkgate St
 42a Parkgate St, Dublin 8

Drawing Title:
 Application 01 - Proposed East and South Courtyard Elevations

Job No. P24-216D	Sheet Size: A1_Landscape	Scale @A1: As indicated
Issue Date: 20.03.2026	Drawn By: RAU	Reviewed By: PK

Status S0	Purpose of Issue Planning Permission
---------------------	--

Project - System - Spatial Zone - Level - Type - Originator - Role - Number PGS-02-SW-ZZZ-DR-RAU-AR-2003	Revision P01
--	------------------------